

Tray 325  
600-800Ah

**FB14RJ-2R**

h3 mm	h2 mm	h1 mm	h4 mm	kg@600mm
5.000	1570	2200	5630	1.400
5.300	1670	2300	5930	1.400
5.750	1820	2450	6380	1.400
5.900	1870	2500	6530	1.400
6.200	1970	2600	6830	1.400
6.500	2070	2700	7130	1.400
6.800	2170	2800	7430	1.400
7.100	2270	2900	7730	1.350
7.825	2570	3200	8455	1.350
8.375	2820	3450	9205	1.200
8.825	2970	3600	9455	1.150
9.025	3070	3700	9655	1.050
9.325	3170	3800	9955	1.000
9.625	3270	3900	10255	950

**FB16RJ-2R**

5.000	1570	2200	5630	1.600
5.300	1670	2300	5930	1.600
5.750	1820	2450	6380	1.600
5.900	1870	2500	6530	1.600
6.200	1970	2600	6830	1.600
6.500	2070	2700	7130	1.600
6.800	2170	2800	7430	1.600
7.100	2270	2900	7730	1.600
7.825	2570	3200	8455	1.600
8.375	2820	3450	9205	1.500
8.825	2970	3600	9455	1.400
9.025	3070	3700	9655	1.400
9.325	3170	3800	9955	1.300
9.625	3270	3900	10255	1.300

**FB20RJ-2R**

4.825	1570	2200	5455	2.000
5.125	1670	2300	5755	2.000
5.575	1820	2450	6205	2.000
6.025	1970	2600	6655	2.000
6.325	2070	2700	6955	1.900
6.625	2170	2800	7255	1.900
7.075	2320	2950	7705	1.800
7.825	2570	3200	8255	1.700
8.375	2820	3450	9205	1.600
8.825	2970	3600	9455	1.500
9.025	3070	3700	9655	1.500
9.325	3170	3800	9955	1.400
9.625	3270	3900	10255	1.300

**FB20RJ-2R  
(heavy duty)**

8.725	2970	3600	9355	1.600
9.025	3070	3700	9655	1.500
9.225	3270	3900	9855	1.450
9.825	3470	4100	10455	1.300
10.025	3670	4300	10655	1.300
10.325	3770	4400	10955	1.250
10.625	3870	4500	11255	1.150
10.925	4070	4700	11555	1.050
11.225	4170	4800	11855	950
11.525	4270	4900	12155	850

# AR-2R SERIES

## 1.2 TO 2.0 TON



Simple, ergonomic controls

The AR-2R has been developed around an alternating current (AC) power system to provide the highest levels of performance in terms of hours of usage and operator comfort.

The robust 6kW (KB 60 minutes) traction engine can reach a high level of torque with a very flat curve for powerful but gradual levels of acceleration, excellent regenerative braking and surprisingly nimble reversing. The operator can select up to four different levels of traction in addition to slow speed on the display.



Exceptional comfort

The hydraulic pump with internal gears is particularly silent and powered by an 11.5kW (ED 15%) motor. Ergonomic micro levers that control the opening of the proportional electrovalves by means of a logic system operate the various hydraulic functions. All the functions can be operated at the same time and the responsiveness of the system can be set depending upon the requirements of the operator.

All the engines are completely encapsulated so do not require cleaning or the removal of residues or dust that normally accumulate in unshielded motors.



Very manoeuvrable in tight spaces

The AR-2R series provides incomparable operator comfort due to the careful positioning of the controls, all electric including the parking brake and the exceptional visibility through both the mast and the overhead guard.

The strong fabric seat features a shock absorber system and a high range of adjustments depending upon the weight and height of the operator. The steering wheel has a reduced diameter of 200mm and can be tilted. Also available upon request are an electrically operated platform (100mm), heated seats or imitation leather seats.

Standard equipment includes a multi-functional LED display with battery-state-of-charge indicator, hour meter, drive wheel position indicator and alarms. Also available as options are the height pre-selector and the fork height indicator.

Driving comfort is optimal due to the fully electric power steering system together with the travel direction selector as standard features. The wheel can cover an angle of 183° with four turns of the steering wheel allowing for easy disengagement even from the edge of shelves. 360° steering is also available as an option to further increase productivity and the pleasure of driving.

Designed by CAD systems, the truck frame has



Good fork tip visibility



AC technology

a very low center of gravity for greater residual capacity stability even at the highest lift heights. The extensive use of robotic welding and contoured sheet metal ensures that the truck remains rigid and strong in all applications, thus increasing the level of confidence of the operator.

The TFV masts are available up to 11,500mm of lift and include the tilt and side shift functions on the fork carriage assembly as standard features, with clear benefits in terms of residual capacity and energy consumption. The truck also includes a shock absorber system when retracting to reduce the strain felt by the operator.

The truck has three braking systems:

- Energy regenerative braking as the service brake
- Negative electromagnetic brake on the traction engine as the parking and emergency brake
- Mechanical/hydraulic brake on the load wheels as the pedal brake

The hydraulic and traction systems are managed by a single logic unit which is connected to the other parts by means of CAN-BUS thus ensuring a high level of reliability that is further increased by the use of IP45 standard parts.

Thanks to the technical features and the quality of the parts, maintenance is reduced thus ensuring fewer stoppages of the machine.

The following are available as options:

- -30°C cold stores version with or without a cab
- 360° steering
- Height pre-selector
- Additional 5th hydraulic gear
- Telecamera on the forks
- Electrically operated platform (100mm)
- Side removal of battery with support
- Extra protection for the load
- Function and operation indicators

Do not hesitate to contact your nearest Komatsu Forklift dealer: you will be visited by one of our experts who will analyse your requirements and recommend the best solution for you in terms of investment and application.

Please visit our web site [www.komatsuforklift.net](http://www.komatsuforklift.net) to see the complete range of Komatsu Forklift products. You can also register to gain access to the reserved areas of the web site and receive information about new products.

# KOMATSU

Part Number: PKSW016EN  
Form.No: AR(2R)-S-E-P-06/04

This brochure may contain equipment that are not available in your area. Please consult your Komatsu Forklift distributor for those items you may require. Materials and specifications are subject to change without notice.

# AR-2R SERIES

1.2 TO 2.0 TON



**Rider Reach Truck**

- AC technology with encapsulated engines for greater performance and reduced maintenance
- Large, comfortable operator cab with ergonomic controls
- Full power steering for exceptional agility and responsiveness
- Four traction curves to choose from in addition to the slow speed feature
- High visibility due to the shape of the masts and the overhead guard
- Masts with reduced flexion and high residual capacities up to 11,500 mm

# AR-2R SERIES

## 1.2 TO 2.0 TON

		Tray	323	323	324	325	323		
<b>CHARACTERISTICS</b>	1,2	Model	FB12RJ-2R	FB14RJ-2R					
	1,3	Power unit							
	1,4	Operator type							
	1,5	Loading capacity	Q (t)	1,2	1,4				
	1,6	Centre of gravity	c (mm)						
	1,8	Load distance,centre of drive axle to fork	x (mm)	418	376	303	230	438	
	1,9	Wheel base	y (mm)	1370	1370				
	<b>WEIGHTS</b>	2,1	Weight without battery	kg	2890	3110	3310	3500	3140
		2,3	Axles unladen weight	kg	1940 / 950	2020 / 1090	2070 / 1240	2100 / 1400	2070 / 1070
2,4		Axles laden weight - reach out	kg	785 / 3305	690 / 3820	800 / 3910	895 / 4005	620 / 4120	
2,5		Axles laden weight - reach in	kg	1780 / 2310	1790 / 2720	1765 / 2945	1720 / 3180	1890 / 2850	
<b>TYRES - FRAME</b>		3,1	Tyre type						
	3,2	Size of traction wheels	mm						
	3,3	Size of load wheels	mm						
	3,5	Wheels:number at front/back (x = traction)							
	3,6	front track (drive wheels)	b10 (mm)						
	3,7	Rear track (load wheels)	b11 (mm)						
	<b>DIMENSIONS</b>	4,1	Tilt (forward/back)	degree (°)					
4,2		Closed mast height	h1 (mm)					2200	
4,3		Free lift	h2 (mm)					1570	
4,4		Lifting range	h3 (mm)	5015	5000				
4,5		Height of mast extended	h4 (mm)	5645	5630				
4,7		Height of driver's overhead guard	h6 (mm)						
4,8		Height of seat	h7 (mm)						
4,10		Height of reach legs	h8 (mm)						
4,19		Total length	l1 (mm)	2358	2400	2473	2546	2410	
4,20		Length to fork face	l2 (mm)	1208	1250	1320	1396	1260	
4,21		Total width	b1 (mm)						
4,22		Fork dimensions	s/e/l (mm)	40 / 100 / 1150	40 / 100 / 1150				
4,23		Fork carriage							
4,25		Forks spread (outside)	b5 (mm)						
4,26		Reach legs width (inside)	b4 (mm)						
4,28		Reach	l4 (mm)	626	586	513	440	658	
4,31		Ground clearance under mast - laden	m1 (mm)						
4,32		Ground clearance at wheel-base centre - laden	m2 (mm)						
4,33		90°stacking aisle 1000 x 1200 crosswise	Ast3 (mm)	2669	2698	2752	2809	2724	
4,34		90°stacking aisle 1200 x 800 crosswise	Ast3 (mm)	2712	2748	2815	2882	2762	
4,35	Minimum turning radius	Wa (mm)	1633						
4,37	Length including reach legs	l7 (mm)	1798						
<b>PERFORMANCES</b>	5,1	Travel speed (loaded/unloaded)	km/h						
	5,2	Lifting speed (loaded/unloaded)	m/s	0,38 / 0,6	0,36 / 0,60				
	5,3	Lowering speed (loaded/unloaded)	m/s	0,52 / 0,44	0,52 / 0,46				
	5,7	Max gradient KB30' (Loaded/unloaded)	%				10 / 15		
	5,8	Max climbing gradient KB5' (loaded/unloaded)	%				10 / 15		
	5,10	Service brake							
<b>EL. MOTORS</b>	6,1	Traction motor,performance KB 60'	kW						
	6,2	Lifting motor,performance 15% ED	kW						
	6,3	Battery standard							
	6,4	Voltage / Rated capacity	V / Ah	48 / 420L	48 / 420L	48 / 560L	48 / 700L	48 / 420L	
	6,5	Weight of battery (+/-5%)	kg	750	750	940	1120	750	
	6,6	Power consumption according to VDI cycle	kWh/h	4,6	4,9				
<b>OTHERS</b>	8,1	Type of control							
	8,2	Working pressure for attachment	bar						
	8,3	Oil capacity	l/min						
	8,4	Noise level for operator	dB (A)						

324	325	324	325	325
FB16RJ-2R		FB20RJ-2R		FB20RJ-2R with Heavy Duty Mast
Electric				
Seated				
1,6		2,0		
600				
365	242	437	364	364
1442		1514		1514
3340	3530	3520	3710	4150
2125 / 1215	2160 / 1370	2280 / 1240	2330 / 1380	2480 / 1670
730 / 4210	830 / 4300	675 / 4845	775 / 4935	755 / 5395
1860 / 3080	1820 / 3310	2070 / 3450	2015 / 3695	2170 / 3980
VULKOLLAN				
343 x 135				
310 x 100				
1x / 2				
/				
1140				
2/4				
				3600
				2970
			4825	8725
			5455	9355
2200				
1050				
330				
2483	2556	2483	2556	2556
1333	1406	1333	1406	1406
1250				
50 / 100 / 1150				
FEM II B				
620				
914				
585	512	657	586	586
100				
76				
2775	2868	2792	2844	2844
2827	2940	2831	2896	2896
1702			1770	
1870			1942	
11/11				
0,32 / 0,60		0,28 / 0,48		0,26 / 0,26
0,54 / 0,46		0,50 / 0,40		0,50 / 0,50
			9,5 / 15	9 / 15
			9,5 / 15	9 / 15
Electric/Hydraulic				
6				
11,5				
IEC 254 - 2, C				
48 / 560L	48 / 700L	48 / 560L	48 / 700L	48 / 700L 48 / 600
940	1120	940	1120	1120 1119
5,2			6,3	
AC INVERTER				
140				
18				
< 70				

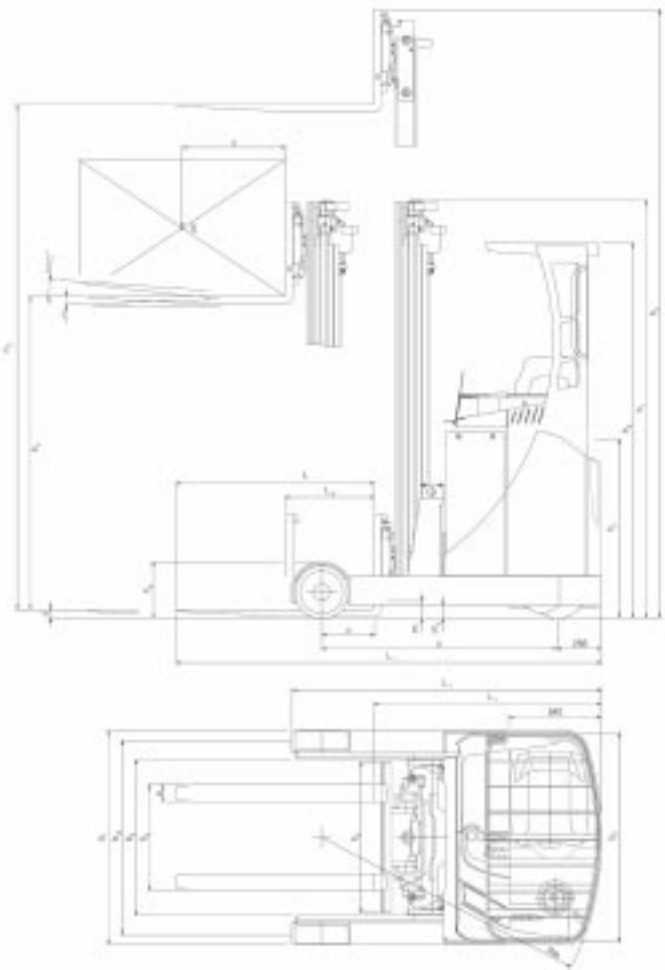

Tray 323  
360-465Ah

FB 12RJ-2R					
h <sub>3</sub> mm	h <sub>2</sub> mm	h <sub>1</sub> mm	h <sub>4</sub> mm	kg@600mm	
5.015	1570	2200	5645	1.200	
5.165	1620	2250	5795	1.200	
5.315	1670	2300	5945	1.200	
5.615	1770	2400	6245	1.200	
5.765	1820	2450	6395	1.200	
5.915	1870	2500	6545	1.150	
6.215	1970	2600	6845	1.100	
6.515	2070	2700	7145	1.000	
FB 14RJ-2R					
5.000	1570	2200	5630	1.400	
5.300	1670	2300	5930	1.400	
5.750	1820	2450	6380	1.400	
5.900	1870	2500	6530	1.350	
6.200	1970	2600	6830	1.350	
6.500	2070	2700	7130	1.300	
6.800	2170	2800	7430	1.250	
7.100	2270	2900	7730	1.250	
FB 16RJ-2R					
5.000	1570	2200	5630	1.600	
5.300	1670	2300	5930	1.600	
5.750	1820	2450	6380	1.600	
5.900	1870	2500	6530	1.600	
6.200	1970	2600	6830	1.500	
6.500	2070	2700	7130	1.500	
6.800	2170	2800	7430	1.400	
7.100	2270	2900	7730	1.400	

**KOMATSU**

WWW.KOMATSUFORKLIFT.NET



Tray 324  
480-620Ah

#### FB12RJ-2R

h3 mm	h2 mm	h1 mm	h4 mm	kg@600mm
5.015	1570	2200	5645	1.200
5.165	1620	2250	5795	1.200
5.315	1670	2300	5945	1.200
5.615	1770	2400	6245	1.200
5.765	1820	2450	6395	1.200
5.915	1870	2500	6545	1.200
6.215	1970	2600	6845	1.150
6.515	2070	2700	7145	1.050

#### FB14RJ-2R

5.000	1570	2200	5630	1.400
5.300	1670	2300	5930	1.400
5.750	1820	2450	6380	1.400
5.900	1870	2500	6530	1.400
6.200	1970	2600	6830	1.400
6.500	2070	2700	7130	1.400
6.800	2170	2800	7430	1.350
7.100	2270	2900	7730	1.300
7.825	2570	3200	8455	1.250
8.375	2820	3450	9205	1.100
8.825	2970	3600	9455	1.050
9.025	3070	3700	9655	950
9.325	3170	3800	9955	850
9.625	3270	3900	10255	800

#### FB16RJ-2R

5.000	1570	2200	5630	1.600
5.300	1670	2300	5930	1.600
5.750	1820	2450	6380	1.600
5.900	1870	2500	6530	1.600
6.200	1970	2600	6830	1.600
6.500	2070	2700	7130	1.600
6.800	2170	2800	7430	1.600
7.100	2270	2900	7730	1.600
7.825	2570	3200	8455	1.600
8.375	2820	3450	9205	1.400
8.825	2970	3600	9455	1.400
9.025	3070	3700	9655	1.300
9.325	3170	3800	9955	1.300
9.625	3270	3900	10255	1.200

#### FB20RJ-2R

4.825	1570	2200	5.455	2000
5.125	1670	2300	5.755	2000
5.575	1820	2450	6.205	1900
6.025	1970	2600	6.655	1800
6.325	2070	2700	6.955	1700
6.625	2170	2800	7.255	1700